

## TCJ INSTALLATION ON H300 VALVE ALREADY ON SERVICE

- 1 Switch off the main electrical power, stand the car on the pit buffers, close the shut-off valve and discharge the pressure of the valve.
- 2 Remove the plug (alley key 5 mm) and remove the jet under the plug (alley key 3 mm).

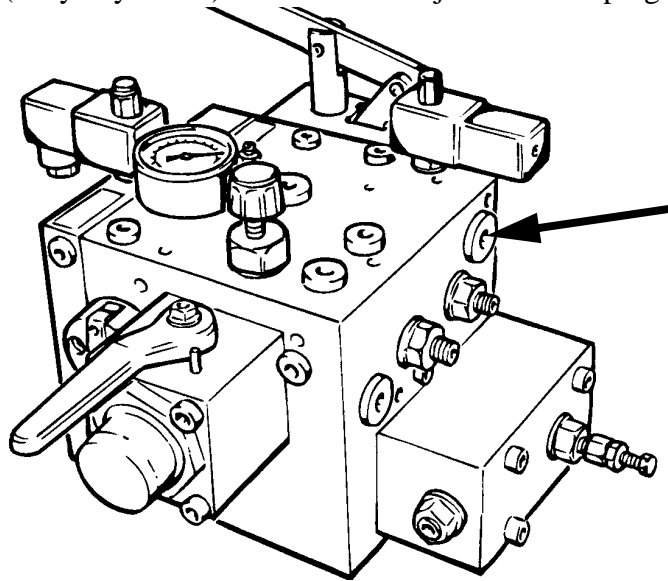

- 3 Install the new jet (hole 1 mm) shipped with the TCJ instead of the removed one (alley key 3 mm).
- 4 Screw by hand the TCJ into the valve body until mechanical stop.

**WARNING: do not force the TCJ to avoid damaging it.**

- 5 Turn the TCJ 3 rounds back and lock with the nut.

**WARNING: in order to avoid TCJ damage do not close the nut too hard.**

- 6 Put on service the elevator, drive the car up and down a few time to purge the air from the valve.
- 7 Check the deceleration to levelling speed. With the locking nut loosen, if the deceleration is to hard turn clockwise the screw TCJ, 1/6 turn per time, if the deceleration in too smooth turn anticlockwise the screw TCJ, 1/6 turn per time. Lock the TCJ by the nut.